

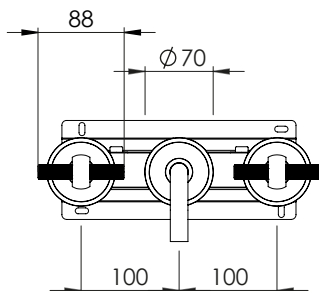

BUILT-IN BASIN MIXER 3 HOLES SPOUT 200 REUBEN

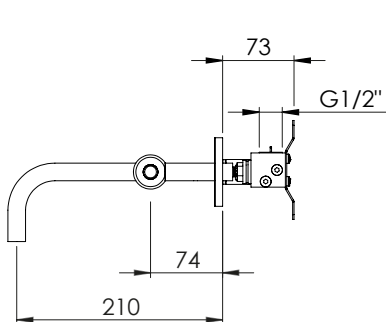

Technical Characteristics

Brushed brass with knurled nickel bar
Lacquered finish

Product Characteristics

The materials used in the construction of this product have been carefully chosen to fulfill the intended function.

Components Ceramic Headworks:

- Recommended working pressure: 1-5 bar
- Recommended temperature: $\leq 65^{\circ}\text{C}$
- Life Cycle: > 200.00
- Ceramic: A12 03 96% Aerator: M16.5X1

Cleaning

Normal cleaning should only be done with mild liquid soap in warm water.

Do not use disinfectant products that contain alcohol, ammonia, phosphoric or, acetic acids.

Quality

All LONDON BASIN COMPANY LTD products are 100% checked during the packaging process, ensuring their tightness and functionality.

Accessories

Replacement accessories are not included with this product.